

**Presse piegatrici
compatte**

Compact press brakes



CE

© 2000 - TEDA S.r.l. All Rights Reserved

Speedy Compact
16.5 cnc



BREVETTO DEPOSITATO
PATENT PENDING



LICENZA ABIEMME

AZIENDA CON SISTEMA QUALITÀ
CERTIFICATO DA DNV
=UNI EN ISO 9001/2000=



teda
TECNOLOGIE ELETTRONICHE
E MECCANICHE

Precisa

Precise

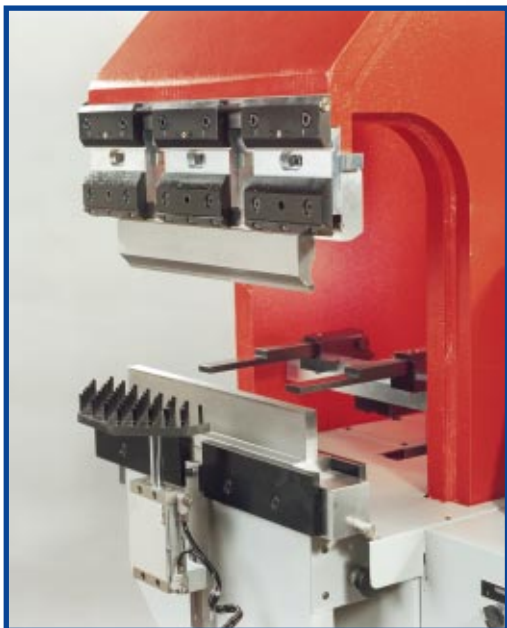

Tre assi controllati e gestiti sequenza per sequenza da CN, con calcolo automatico dell'angolo di piega.

- asse Y idraulico con retroazione, dotato di riga ottica centesimale
- asse X per la profondità di piegatura con testine removibili e dotate di nonio
- asse R per l'alzata del riferimento.

Three axes controlled and handled by NC, with automatic calculation of the bending angle.

- *Y hydraulic axis with feedback, equipped with optical centesimal stripe*
- *X axis for the bending depth with removable fingers equipped with vernier*
- *R axis for the reference lift.*

Sicura

Safe

Le dimensioni ridotte permettono di eliminare le protezioni laterali perché l'intera lunghezza della macchina si trova sempre all'interno della visuale dell'operatore.

The reduced dimensions allow the elimination of the lateral protections: the whole length of the machine is always placed inside the operator's view.



CARATTERISTICHE TECNICHE SC165 cnc

SC165 cnc FEATURES

Forza massima di lavoro / <i>Maximum working strenght</i>	kN	160
Distanza tra i montanti / <i>Distance between table and ram</i>	mm	380
Incavo / <i>Gap</i>	mm	200
Lunghezza massima / <i>Maximum lenght</i>	mm	550
Distanza tavola-pestone / <i>Distance between table and ram</i>	mm	400
Corsa massima / <i>Maximum stroke</i>	mm	250
Velocità di avvicinamento massimo con barriere / <i>Maximum rising speed with barriers</i>	mm/s	100
Velocità di lavoro massimo / <i>Maximum working speed</i>	mm/s	10
Velocità di ritorno massimo / <i>Maximum lowering speed</i>	mm/s	125
Asse X (corsa utile) / <i>X axis (useful stroke)</i>	mm	400
Asse R (corsa utile) / <i>R axis (useful stroke)</i>	mm	120
Massa netta / <i>Net mass</i>	kg	1320

Efficiente

Efficient

Nessun ostacolo laterale: libertà di sfilamento e manipolazione anche dei pezzi più complessi.

No lateral obstacles: also the most complex pieces can be shifted and manipulated with absolute freedom.

Unica Unique

La forma innovativa del pestone permette l'esecuzione di profili ad U senza limiti di profondità.

The innovative shape of the ram allow the execution of U profiles without any depth limitation.

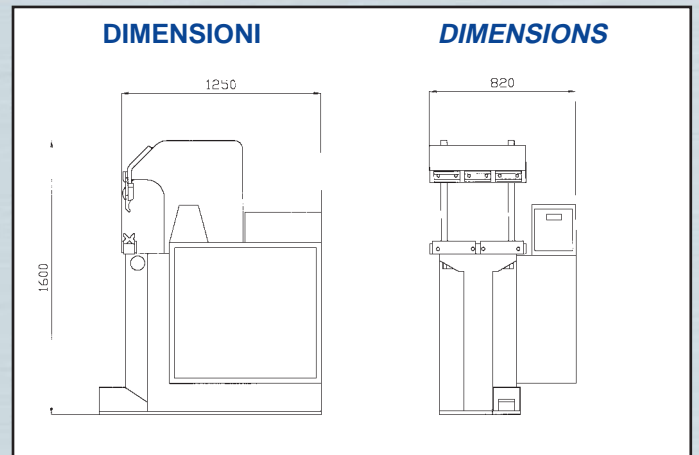
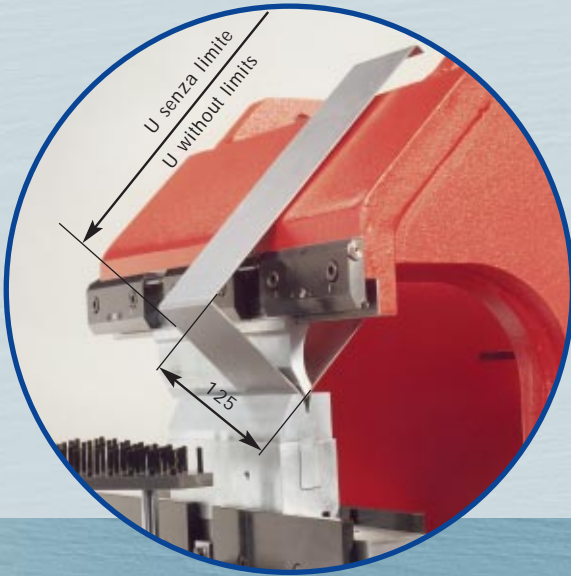

Compatta Compact

Così compatta da non richiedere alcuna fondazione.
Rigidità strutturale garantita e flessione ridotta al minimo.

*So compact that it doesn't need any foundation.
Structural stiffness and deflection reduced to the minimum.*

Completa Complete

SC 165 cnc può essere dotata di diversi OPTIONAL, tra cui:

SC 165 cnc can be equipped with several OPTIONAL, such as:



- sostegno pneumatico bistabile per facilitare la manipolazione di piccoli pezzi.
- *pneumatic fore support to make easier the manipulation of small pieces.*



- sistema di cambio rapido utensili ABM per punzoni e matrici. Disponibile in diverse soluzioni, per rispondere ad ogni necessità del cliente.
- *quick tools change ABM for punches and dies Available in several different solutions, to fulfil any customer's need.*



**Cambio rapido utensili
su presse piegatrici**

*Quick tools change
on press brakes*



Squadre per utensili

Tools squares



**Posizionatore anteriore
per cesoia**

*Front positioner
for shears*



Armadi porta utensili

Tooling cabinets



**Registro a controllo numerico
per presse piegatrici**

*Numerical control
backgauge for press brakes*



**Squadre mobili
di sostegno**

*Mobile support
squares*



**Utensili per
presse piegatrici**

Press brakes tools



**Presse piegatrici
compatte**

*Compact
press brakes*